

# AM SOLUTIONS™ REQUEST FOR QUOTE

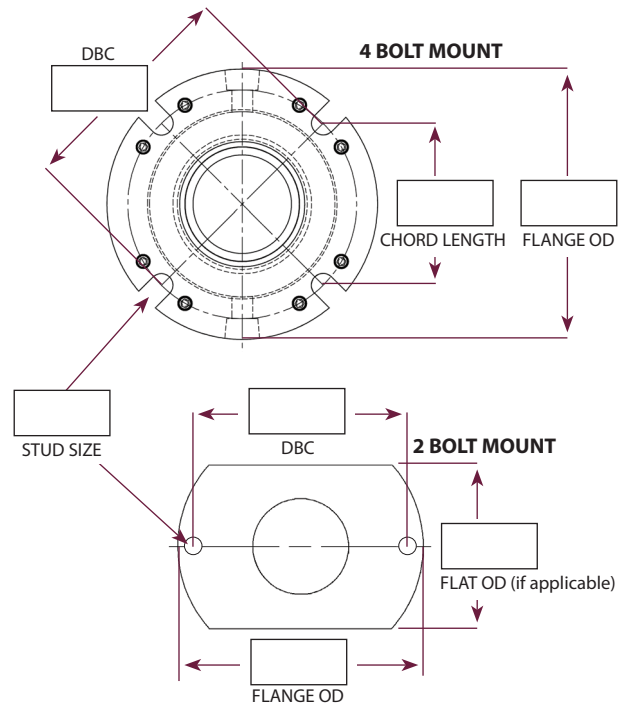
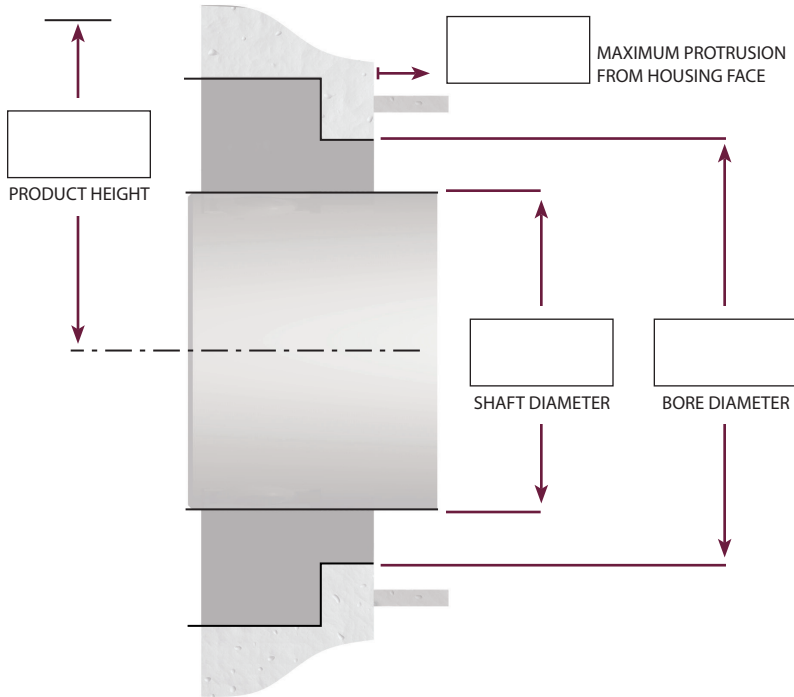

MEASUREMENTS: US Standard (three decimal places) Metric (two decimal places)

## Data Needed For Quote

**VENTED TO ATMOSPHERE:** Yes No  
**SEALING MEDIUM:** Instrument Air Plant Air Nitrogen  
**CAN SEALING MEDIUM ENTER PRODUCT:** Yes No  
**SEAL TYPE:** Split Solid  
**EQUIPMENT:** \_\_\_\_\_  
**SHAFT MATERIAL:** \_\_\_\_\_  
**CURRENT SEALING SOLUTION:** Lip Packing  
 Other \_\_\_\_\_  
**SHAFT POSITION:** Horizontal Vertical Up Vertical Down  
**PRODUCT TO BE SEALED:** \_\_\_\_\_  
**PRODUCT/PROCESS PRESSURE:** \_\_\_\_\_  
**RPM:** \_\_\_\_\_  
**MISALIGNMENT:** DRO \_\_\_\_\_ Axial Movement \_\_\_\_\_  
**TEMPERATURE AT SEAL:** °C °F Min \_\_\_\_\_ Max \_\_\_\_\_  
**TEMPERATURE OF PRODUCT:** \_\_\_\_\_

**BOLT MOUNT:** 2 4 Other \_\_\_\_\_  
**SEAL MATERIAL:** Bronze Stainless Other \_\_\_\_\_  
**FOOD GRADE:** FDA USDA Not Applicable  
**O-RING MATERIAL:** \_\_\_\_\_  
**CONTACT FOR QUESTIONS:** \_\_\_\_\_

## BRIEFLY DESCRIBE THE APPLICATION

### FOR EQUIPMENT ABOVE 121°C (250°F)

**SHAFT GROWTH:** mm in \_\_\_\_\_  
**FULL OPERATING TEMPERATURE RANGE:**  
 °C °F Min \_\_\_\_\_ Max \_\_\_\_\_

Email RFQ to [info@inpro-seal.com](mailto:info@inpro-seal.com) or your local Inpro/Seal Representative



**INPRO/SEAL®**  
a DOVER company

EXPERT ENGINEERING. PROVEN RESULTS.